

PRODUCT REFERENCE GUIDE

STANDARD AND
CUSTOM ENGINEERED
STRAPPING PRODUCTS

YOUR SUCCESS IS OUR BUSINESS

Complete Strapping & Unitizing Solutions

Samuel Packaging Systems Group manufactures and supplies a broad range of steel and plastic strapping, standard and custom engineered unitizing equipment – from manual and pneumatic tools, semi and fully automatic strapping machines to large turnkey packaging and unitizing systems.

Samuel's comprehensive in-house research and engineering capabilities, with state-of-the-art CAD systems technology, offers customers complete packaging and unitizing solutions from a single source. Samuel's engineering expertise for example takes customers' unitizing requirements, from the initial concept, into advanced CAD design engineering, through to fabrication and installation.

Our products and systems can be found in virtually every industry and are supported by a comprehensive sales, customer service and distribution network.

Steel Strapping



Plastic Strapping

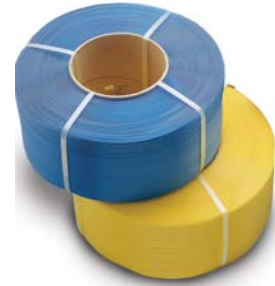

Hand Tools



Plastic Strapping Machines



Strapping Heads



Industrial Strapping Machines



Coding and Labelling Equipment



Stretch Wrappers



Balers



Stretchwrap

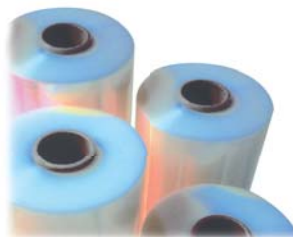

TABLE OF CONTENTS

Steel Strapping	2-3
Polyester Strapping	4
Polypropylene Strapping	5
Steel Strapping Seals	6
Plastic Strapping Seals/Polyester Cord Strapping	7
Steel Strapping Tensioners	8
Steel Strapping Sealers	9
Seal and Sealless Steel Strapping Combination Tools	10
Plastic Strapping Tools	11
Dispensers for Steel and Plastic Strapping/Manual Cutters	12
Accessories	13
Stretch Wrap Equipment	14
Stretch Films	15
Economy Plastic Strapping Machines	16
RQ-8 Automatic Strapping Machines	17
Stainless Steel Strapping Machines	18
Coding and Labeling	19
Coding and Labeling Applications	20
Fully Automated Machine Systems	21
Dispensers for Fully Automated Equipment	22
Edgeboard	23
Dunnage Bags	24
Balers/ Wire Products	25



The strapping systems and equipment presented in this catalogue have been tested and proven in the field, and carry our guarantee of quality in design, engineering and manufacturing.

Samuel Packaging Systems Group is one of the few companies in North America manufacturing both steel and plastic strapping. This capability gives us total control to provide you with prime quality and trouble-free strapping material.

Samuel Strapping sales representatives and service personnel are specialists in providing counsel and recommendations on industrial packaging materials and methods.

STEEL STRAPPING

Samuel Steel Strapping is available in a wide range of sizes and gauges to accommodate your strapping requirements. Our edge conditioned strapping ensures a safe, rounded edge that is problem-free during application. Our High Tensile and Heavy Duty strapping conforms to Government, Railroad and ASTM specifications and is marked in accordance with the requirements of the Association of American Railroads.

Finishes

All finishes are treated with a hard wax coating – a special Samuel “hot dip” process. This lubrication allows the strapping to flow smoothly in automatic machines, tools and around corners of all products, skids, crates or cartons.

Painted

A hard baked-on gloss applied to both sides and edges helps the flow characteristics of the strapping.

Zinc

Commonly used for prolonged outside storage, this finish offers greater rust resistance than regular painted material.

Jumbo Coils

For high volume applications, certain strap sizes are available in jumbo coils, ranging in weight from 250-2000 lbs. (110-900 kg). Coil face ranges from 6" (152.4mm), 7½" (190.5mm), 8" (203.2mm) and 12" (304.8mm).

Packaging

Oscillated wound steel strapping coils are shrouded. Skids are normally shroud wrapped with corrugated for protection in transit.



Packaging

Standard Winding	Coil Dimensions						Available in				
	Face in	Face (mm)	Inside Diam. in	Inside Diam. (mm)	Outside Diam. in	Outside Diam. (mm)	Approx. Weight lbs	Approx. Weight (kg)	Shroud Pack	Std. Skid Shipped lbs	Std. Skid Shipped (kg)
Oscillated	2 7/8	(73)	16	(406)	23	(584)	105	(47)	•	Approx. 1300	(585)
Ribbon	Width of Strap		16	(406)	27	(686)	60-110	(27-50)	Bare Coils	1680-2645	(760-1200)



Ribbon Wound Coil



Oscillated Wound Coil

STEEL STRAPPING

Standard Duty

Product Code	Width		Thickness		Average Strength		Length/Weight		Average Coil Weight		Coil Winding			Strap Finish	
	in	(mm)	in	(mm)	lbs	(N)	ft/lbs	(m/kg)	lbs	(kg)	OSC	RIB	WAX	PTD	ZINC
16038S	3/8	(10)	.015	(.38)	675	(3000)	52.4	(35.2)	100-105	(45-47)	•		•	•	
16051S	3/8	(10)	.020	(.51)	900	(4000)	39.3	(26.4)	100-105	(45-47)	•		•	•	
16338S	1/2	(13)	.015	(.38)	900	(4000)	39.3	(26.4)	100-105	(45-47)	•		•	•	
16351S	1/2	(13)	.020	(.51)	1200	(5340)	29.4	(19.8)	100-105	(45-47)	•		•	•	
16358S	1/2	(13)	.023	(.58)	1380	(6140)	25.6	(17.2)	100-105	(45-47)	•		•	•	
16638S	5/8	(16)	.015	(.38)	1125	(5000)	31.4	(21.1)	100-105	(45-47)	•		•	•	
16646S	5/8	(16)	.018	(.46)	1375	(6115)	26.2	(17.6)	100-105	(45-47)	•		•	•	
16651S	5/8	(16)	.020	(.51)	1500	(6670)	23.6	(15.9)	100-105	(45-47)	•		•	•	
16658S	5/8	(16)	.023	(.58)	1725	(7670)	20.5	(13.8)	100-105	(45-47)	•		•	•	
16938S	3/4	(19)	.015	(.38)	1350	(6000)	26.2	(17.6)	100-105	(45-47)	•		•	•	
16946S	3/4	(19)	.018	(.46)	1620	(7200)	21.8	(14.6)	100-105	(45-47)	•		•	•	
16951S	3/4	(19)	.020	(.51)	1800	(8000)	19.6	(13.2)	100-105	(45-47)	•		•	•	
16958S	3/4	(19)	.023	(.58)	2070	(9200)	17.1	(11.5)	100-105	(45-47)	•		•	•	

High Tensile

86351S	1/2	(13)	.020	(.51)	1500	(6670)	29.4	(19.8)	100-105	(45-47)	•		•	•	•
86358S	1/2	(13)	.023	(.58)	1725	(7670)	25.6	(17.2)	100-105	(45-47)	•		•	•	•
86651S	5/8	(16)	.020	(.51)	1875	(8340)	23.6	(15.9)	100-105	(45-47)	•		•	•	•
86658S	5/8	(16)	.023	(.58)	2150	(9560)	20.5	(13.8)	100-105	(45-47)	•		•	•	•
86951S	3/4	(19)	.020	(.51)	2250	(10000)	19.6	(13.2)	100-105	(45-47)	•		•	•	•
86956S	3/4	(19)	.022	(.55)	2615	(11630)	17.5	(11.7)	100-105	(45-47)	•		•	•	•
86958S	3/4	(19)	.023	(.58)	2600	(11560)	17.1	(11.5)	100-105	(45-47)	•		•	•	•
86964S	3/4	(19)	.025	(.64)	2800	(12450)	15.7	(10.5)	100	(45)	•		•	•	•
86974S	3/4	(19)	.029	(.74)	3320	(14770)	13.5	(9.0)	100-105	(45-47)	•		•	•	•
86979S	3/4	(19)	.031	(.79)	3500	(15560)	12.7	(8.5)	100-105	(45-47)	•	•	•	•	•
86989S	3/4	(19)	.035	(.89)	3900	(17350)	11.2	(7.5)	100-105	(45-47)	•	•	•	•	•
86912R	3/4	(19)	.044	(1.12)	4950	(22020)	8.71	(5.9)	60	(27)	•		•		
86974R	3/4	(19)	.029	(.74)	3320	(14770)	13.5	(9.0)	60	(27)	•		•		
86979R	3/4	(19)	.031	(.79)	3500	(15560)	12.7	(8.5)	60	(27)	•		•		
86989R	3/4	(19)	.035	(.89)	3900	(17350)	11.2	(7.5)	60	(27)	•		•		
86264R	1 1/4	(32)	.025	(.64)	4650	(20680)	9.4	(6.3)	100	(45)	•		•	•	•
86279R	1 1/4	(32)	.031	(.79)	5500	(24460)	7.6	(5.1)	100	(45)	•		•	•	•
86289R	1 1/4	(32)	.035	(.89)	5800	(25800)	6.72	(4.5)	100	(45)	•		•	•	•
86212R	1 1/4	(32)	.044	(1.12)	8350	(37140)	5.35	(3.6)	100	(45)	•		•	•	•
86112R	2	(51)	.044	(1.12)	12300	(54710)	3.34	(2.2)	100	(45)	•		•	•	•

Extra High Tensile

26212R	1 1/4	(32)	.044	(1.12)	9550	(42485)	5.35	(3.59)	100-105	(45-47)	•		•	•	•
26227R	1 1/4	(32)	.050	(1.27)	11185	(49755)	4.71	(3.16)	100-105	(45-47)	•		•	•	•
26245R	1 1/4	(32)	.057	(1.45)	12065	(53675)	4.12	(2.77)	100-105	(45-47)	•		•	•	•

For other strap sizes and gauges, please contact your Samuel sales representative.

Standard Duty

Manufactured to meet rigid quality specifications and close tolerances, Samuel Standard Duty strapping is ideal for all general applications and is available in a number of different finishes.

High Tensile

High Tensile strapping is manufactured for optimum results in every application. Cold rolled steel of a high carbon and manganese analysis is heat treated to ensure uniform tensile and elongation characteristics.

Extra High Tensile

Offers the same advantages of uniform high quality, but in larger cross sections, providing maximum strength and elongation. Use in heavy to extreme duty applications of unitizing and load securement where maximum protection from stress and shocks is required, e.g., lifting loads aboard ships.

Custom Orders

Samuel Steel Strapping can be manufactured to meet your special requirements, whether it be cut-to-length strapping, curved edge, jumbo coils, or pre-punched strapping sizes.

POLYESTER STRAPPING

Savings

Polyester's unique qualities make it one of the best strapping materials to use for securing any type of palletized or unitized load. Depending on the size of steel strapping currently being used, polyester strapping can provide up to a 25% savings in strapping costs. Polyester can eliminate the need for metal seals in certain applications, which provides additional savings and reduces product damage that might occur through the use of other packaging alternatives.

Proven Performance

Samuel Packaging Systems Group Research and Development efforts have led to the introduction of industrial strength polyester strapping, approved by the Association of American Railroads (AAR) for open top and closed rail car shipments of Brick, Lumber and other panel products.

Ease of Disposal

Polyester strapping can be easily disposed of by rolling or bending. Also, it can be cut into small pieces with our HLC-80 Strap Chopper and accumulated for recycling.

Elongation Recovery

Polyester strapping provides approximately 2% elongation at normal work tension, which allows material to stretch. The strapping will recover this elongation however, keeping the strapping tight around the package even if the load settles and shrinks in size.

Moisture & UV Resistant

Because it is plastic, it is moisture resistant and therefore unaffected by rusting that might occur with other packaging alternatives which may stain or affect the quality of your product before it gets to its destination. Our polyester strapping is also UV resistant to protect strapping from long periods of exposure to the sun.

For other strap sizes and gauges, please contact your Samuel sales representative.

Polyester Strapping

Product Code	Width		Gauge		Breaking Strength		Footage		Wax	Colour	Weight	
	in	(mm)	in	(mm)	lbs	(N)	ft	(m)			lbs	(kg)
16" I.D. x 3" Face – 28 Coils Per Skid – 2 Coils/Box												
P1220SKB036J1	1/2	(12)	.020	(.51)	600	(2670)	3600	(1097)		Black	20	(9)
P1225SKB029J1	1/2	(12)	.025	(.64)	750	(3336)	2900	(884)		Black	20	(9)
P5825SKB023J1	5/8	(16)	.025	(.64)	930	(4136)	2300	(701)		Black	20	(9)
16" I.D. x 6" Face – 28 Coils Per Skid – Bulk Packed												
P3821SMT096H2	3/8	(10)	.020	(.51)	460	(2046)	9600	(2926)		T-Green	43	(20)
P1220SMT090H2	1/2	(12)	.020	(.51)	600	(2670)	9000	(2744)		T-Green	49	(22)
P1220WMT090H9	1/2	(12)	.020	(.51)	600	(2670)	9000	(2744)	•	T-Green	49	(22)
P1228WMT065H9	1/2	(12)	.028	(.71)	800	(3560)	6500	(1982)	•	T-Green	50	(22.6)
16" I.D. x 6" Face – 28 Coils Per Skid – 1 Coil/Box												
P1220SMB072H3	1/2	(12)	.020	(.51)	600	(2670)	7200	(2195)		Black	39	(17.6)
P1225SMB058H3	1/2	(12)	.025	(.64)	750	(3336)	5800	(1770)		Black	40	(18)
P5825SMT044H3	5/8	(16)	.025	(.64)	930	(4136)	4400	(1340)		T-Green	39	(17.6)
P5825SMB046H3	5/8	(16)	.025	(.64)	930	(4136)	4600	(1400)		Black	41	(18.5)
16" I.D. x 6" Face – Embossed Polyester – 28 Coils Per Skid – Bulk Packed												
P1220EMT100H2	1/2	(12)	.020	(.51)	620	(2757)	10000	(3050)		T-Green	49	(22)
P1227EMT082H2	1/2	(12)	.027	(.68)	750	(3336)	8200	(2500)		T-Green	56	(25.5)
16" I.D. x 6" Face – Embossed Polyester – 28 Coils Per Skid – 1 Coil/Box												
P1223EMT082H3	1/2	(12)	.023	(.58)	625	(2780)	8200	(2500)		T-Green	48	(21.5)
16" I.D. x 6" Face – 28 Coils Per Skid – Bulk Packed												
P3819RMT137A2	3/8	(10)	.019	(.48)	425	(1890)	13750	(4190)		T-Green	56	(25.5)
P3821RMT125A2	3/8	(10)	.021	(.53)	470	(2090)	12500	(3810)		T-Green	55	(25)
P7619RMT115A2	7/16	(11)	.019	(.48)	525	(2335)	11550	(3506)		T-Green	56	(25.5)
P7620RMT105A2	7/16	(11)	.020	(.51)	525	(2335)	10500	(3201)		T-Green	51	(23.2)
P7623RMT099A2	7/16	(11)	.023	(.58)	600	(2670)	9900	(3020)		T-Green	56	(25.5)
P7624RMT090A2	7/16	(11)	.024	(.61)	650	(2891)	9000	(2744)		T-Green	56	(25.5)
16" I.D. x 6" Face – 28 Coils Per Skid – Bulk Packed												
P5830SMT038H2	5/8	(16)	.030	(.76)	1100	(4895)	3800	(1160)		T-Green	41	(18.5)
P5835XMG040H9	5/8	(16)	.035	(.89)	1400	(6225)	4000	(1219)	•	Green-AAR	50	(22.5)
P5840SMG040H2	5/8	(16)	.040	(1.02)	1600	(7110)	4000	(1219)		Green	57	(26)
P5840XMG040H9	5/8	(16)	.040	(1.02)	1600	(7110)	4000	(1219)	•	Green-AAR	57	(26)
P5840CMG040H2	5/8	(16)	.040	(1.02)	1290	(5730)	4000	(1219)		Green-AAR	54	(24.5)
P3440TMG030H2	3/4	(19)	.040	(1.02)	1900	(8450)	3000	(914)		Green-AAR	52	(23.5)
Jumbo Coils												
P5835TSG230H7	5/8	(16)	.035	(.89)	1400	(6225)	23000	(7010)		Green-AAR	284	(129)
P5840TSG200H7	5/8	(16)	.040	(1.02)	1600	(7110)	20000	(6096)		Green-AAR	282	(128)
P5840XSG200H7	5/8	(16)	.040	(1.02)	1600	(7110)	20000	(6096)	•	Green-AAR	274	(125)
P5840XSBK200H7	5/8	(16)	.040	(1.02)	1600	(7110)	20000	(6096)	•	Black	274	(125)
P3440TSG175H7	3/4	(19)	.040	(1.02)	1900	(8450)	17500	(5334)		Green-AAR	298	(135)



Super Jumbo Polyester coils

POLYPROPYLENE STRAPPING

Polypropylene Strapping

Product Code	Width		Colour (Alt. colours)	Thickness		Breaking Strength		Footage		Weight	
	in	(mm)		in	(mm)	lbs	(N)	ft	(m)	lbs	(kg)
Hand Grade – 8" I.D. x 8" Face - 24 Coils Per Skid - 1 Coil/Box											
H1230EGB090C7	1/2	(12)	Black	.024	(.61)	300	(1336)	9,000	(2743)	22	(10.0)
H1260EGB072C7	1/2	(12)	Black	.031	(.78)	600	(2225)	7,200	(2196)	32	(14.5)
H5870EGB060C7	5/8	(16)	Black	.029	(.74)	700	(3115)	6,000	(1830)	31	(14.0)
Hand Grade – 16" I.D. x 6" Face - 28 Coils Per Skid - 1 Coil/Box											
H1230EMB090T7	1/2	(12)	Black	.024	(.61)	300	(1336)	9000	(2743)	22	(10.0)
H1250EMB072T7	1/2	(12)	Black	.027	(.68)	500	(2225)	7200	(2196)	24	(10.9)
H1260EMB072T7	1/2	(12)	Black	.031	(.78)	600	(2670)	7200	(2196)	32	(14.5)
H5870EMB060T7	5/8	(16)	Black	.029	(.74)	700	(3116)	6000	(1828)	31	(14.0)
Machine Grade – 8" I.D. x 6" Face - 28 Coils Per Skid - 1 Coil/Box											
M1260EMY072B6	1/2	(12)	Yellow	.031	(.78)	600	(2670)	7200	(2196)	34	(15.0)
Machine Grade – 8" I.D. x 8" Face - 24 Coils Per Skid - 1 Coil/Box											
M0513EDW230H3X	–	(5)	White	.017	(.43)	130	(580)	23000	(7010)	22	(10.0)
M0513EDY240S8	–	(5)	Yellow	.017	(.43)	130	(580)	24000	(7315)	22	(10.0)
M0617EGW200T2	–	(6)	White	.021	(.53)	175	(780)	20000	(6097)	26	(11.7)
M1421EGW170T2	1/4	(6)	White (Y)	.023	(.58)	210	(935)	17000	(5180)	25	(11.0)
M0722EGU164T2	–	(7)	Blue	.026	(.66)	220	(980)	16400	(5000)	26	(11.8)
M3830EGW129S9	3/8	(10)	White (B, C, Y)	.024	(.61)	300	(1336)	12900	(3933)	25	(11.3)
M1230EGW099S9	1/2	(12)	White (B, C, Y)	.024	(.61)	300	(1336)	9900	(3018)	24	(10.8)
M1260EGB072S9	1/2	(12)	Black (W, Y)	.031	(.78)	600	(2670)	7200	(2196)	32	(16.3)
M1260NGW072E8	1/2	(12)	Black	.031	(.78)	600	(2670)	7200	(2196)	26	(11.8)
Machine Grade – 9" I.D. x 8" Face - 24 Coils Per Skid - 1 Coil/Box											
M0617EHY240T4	–	(6)	Yellow (W)	.021	(.53)	170	(755)	24000	(7313)	31	(14.0)
M0620EHY220T4	–	(6)	Yellow	.022	(.55)	200	(890)	20000	(6700)	31	(14.0)
M1421EHY170T4	1/4	(6)	Yellow	.023	(.58)	175	(780)	17000	(5182)	25	(11.3)
M1421EHW170T4	1/4	(6)	White	.023	(.58)	210	(934)	17000	(5182)	25	(11.3)
M3826EHW129T3	3/8	(10)	White (C)	.024	(.61)	260	(1115)	12900	(3933)	24	(10.8)
M3830EHW129T3	3/8	(10)	White (B, C, Y)	.024	(.61)	300	(1336)	12900	(3933)	25	(11.3)
M1230EHW099T3	1/2	(12)	White (B, Y)	.024	(.61)	300	(1336)	9900	(3018)	24	(10.8)
Machine Grade – 16" I.D. x 6" Face - 28 Coils Per Skid - 1 Coil/Box											
M1240EMB089B8	1/2	(12)	Black	.026	(.66)	400	(1780)	8900	(2715)	25	(11.3)
M1250EMW082B6	1/2	(12)	White (B)	.027	(.68)	500	(2225)	8200	(2500)	34	(15.0)
M1250EMC066B8	1/2	(12)	Clear	.027	(.68)	500	(2225)	6600	(2010)	22	(10.0)
M1260EMB072B8	1/2	(12)	Black (C)	.031	(.78)	600	(2670)	7200	(2196)	32	(14.5)
Machine Grade – 9" I.D. x 8" Face - 24 Coils Per Skid - 1 Coils/Box											
M3830EHY129T3	3/8	(10)	Yellow	.024	(.61)	220	(976)	12900	(3933)	26	(11.8)
Machine Grade – 8" I.D. x 8" Face - 24 Coils Per Skid - 1 Coil/Box											
M0513EDW240S8	–	(5)	White	.017	(.43)	130	(578)	24000	(7313)	22	(10.0)
Machine Grade – 8" I.D. x 8" Face - 24 Coils Per Skid - Bulk Pack											
M0512SDC260R5	–	(5)	Clear	.015	(.38)	120	(535)	26000	(7925)	28	(12.7)
M1420SDC167R5	1/4	(6)	Clear (Y)	.018	(.46)	200	(890)	16750	(5106)	28	(12.7)
M1420SDY180R5	1/4	(6)	Yellow	.016	(.41)	200	(890)	18000	(5485)	26	(11.7)
M1420SDC180R5	1/4	(6)	Clear	.016	(.41)	200	(890)	18000	(5485)	26	(11.7)
M7650SDB075R5	7/16	(11)	Black (C)	.025	(.64)	500	(2225)	7500	(2286)	31	(14.0)
Machine Grade – 4" I.D. x 6" Face - 30 Coils Per Skid - Bulk Pack											
M1414SAC200R7	1/4	(6)	Clear (Y)	.014	(.38)	145	(645)	20000	(6097)	25	(11.3)
M1417SAC150R7	1/4	(6)	Clear (Y)	.018	(.46)	170	(755)	15000	(4573)	25	(11.3)
Machine Grade – 16" I.D. x 6" Face - 28 Coils Per Skid - Bulk Pack											
M1250EMB082B6	1/2	(12)	Black (W)	.027	(.68)	500	(2225)	8200	(2500)	28	(12.7)
M1260EMB072B6	1/2	(12)	Black (Y)	.031	(.79)	600	(2670)	7200	(2196)	32	(14.5)
M1275EMB055B6	1/2	(12)	Black	.037	(.94)	750	(3336)	5575	(1700)	33	(15.0)

Polypropylene strapping is the most economical of all strapping material due to its light weight and versatility. It is available in a wide variety of sizes and gauges and offers the greatest elongation of any strapping type, along with good initial recovery characteristics. Samuel polypropylene can be heat sealed with a joint efficiency of 70 to 80%.

By nature, polypropylene strapping is very flexible and simplifies the job of strapping by its ability to mold to contours of odd-shaped or irregular shaped packages.

For other strap sizes and gauges, please contact your Samuel sales representative.



Product Color Code

B – Black C – Clear
 Y – Yellow A – Opaque Green
 W – White T – Translucent Green
 U – Blue

STEEL STRAPPING SEALS

Open

Fast and easy to use, open seals can be placed over the strap before or after tensioning.



Push-Type

The strap is pre-threaded through the seal prior to tensioning. The overlapping flange feature provides the required strength as the tensioner pushes against the edge of the seal.



Thread-On

Also referred to as closed seals, the strap is pre-threaded through the seal prior to tensioning.



Open-Flange

Used for heavy duty or high tensile, the open flange allows placement over the strap, before or after tensioning.



Magazine-Feed

These securely stacked seals are easily loaded into combination strapping tools or power strapping machines.



Standard Duty

Strap Size in (mm)	Seal No.	Seal Type	Std. Pack	Seal Length		Wt. Per Pack		Sealer/Tensioner
				in	(mm)	lbs	(kg)	
3/8 (10)	38-0	Open	2000*	1	(25.4)	9	(4.1)	S-38-0
	38-P	Push	2000*	1	(25.4)	16	(7.3)	S-38-P, CR-25-A, A431
	38-M	Magazine	5000	1	(25.4)	25	(11.3)	S Series, Auto M/C
	38-KL	Magazine	7000	7/8	(22.2)	22	(10.0)	S Series
1/2 (13)	12-0	Open	2000*	1	(25.4)	12	(5.4)	S-12-0
	12-P	Push	2000*	1	(25.4)	22	(10.0)	S-12-P, CR-25-A, A431
	12-SP	Push	2000	7/8	(22.2)	18	(8.2)	S-12-P, S-4-P, A480
	12-M	Magazine	5000	1	(25.4)	29	(13.2)	S Series
	12-KL	Magazine	10500	7/8	(22.2)	36	(16.0)	S Series
	12-AMPS	Magazine	7000	1 1/8	(28.6)	44	(20.0)	S Series
5/8 (16)	58-0	Open	2000*	1	(25.4)	14	(6.4)	S-58-0
	58-P	Push	2000	1	(25.4)	23	(10.4)	S-58-P, CR-25-A, A431
	58-P(028)	Push	2000	1	(25.4)	23	(10.4)	S-58-P, CR-25-A, A480, A431
	58-M	Magazine	5000	1	(25.4)	36	(16.3)	B-145, B-245, S Series
	58-K	Magazine	6000	1 1/8	(28.6)	49	(22.0)	S Series
3/4 (19)	34-0	Open	2000*	1	(25.4)	16	(7.3)	S-34-0
	34-L0	Open	5000/2000†	1 1/4	(31.8)	53/23†	(24.0)/(10.4)	S-34-0
	34-P	Push	2000	1	(25.4)	27	(12.2)	S-34-P, CR-25-A, A431
	34-P(028)	Push	2000	1	(25.4)	28	(12.7)	S-34-P, CR-25-A, A480
	34-M	Magazine	5000	1	(25.4)	36	(16.3)	S Series
	34-KP	Magazine	5000	1 1/8	(28.6)	47	(21.0)	S Series

†U.S. specifications only

* 5000/bx available in US also. Quantities Subject To Change

Heavy Duty

Strap Size in (mm)	Seal No. Can.	Seal Type	Std. Pack	Seal Length		Wt. Per Pack		Recommended Tools	Type of Joint		
				in	(mm)	lbs	(kg)		Notch	Crimp	
3/4 (19)	34-HOF	Open-Flange	2000	1 25/32	(45.2)	45	(20.4)	S6-DNR, S34-N	•		
	34-HT	Thread On	2000	1 25/32	(45.2)	49	(22.2)	S6-DNR, S-34-SN, PS6-SNR	•		
	34-HP	Push	2000	1 25/32	(45.2)	74	(33.6)	S6-DNR, S-34-SN, PS6-SNR, A482-6, CR24A	•		
	34-HM	Magazine	2000	1 1/2	(38.1)	42	(19.1)	S Series		•	
1 1/4 (32)	114-HOF	Open-Flange	1000	2 3/16	(56.0)	45	(20.4)	S-10-DNR, S-10-SN	•		
	114-HT	Thread on	1000	2 3/16	(56.0)	44	(20.0)	S-10-SNR, S-10-DNR, S-10-SN, PS-10-SNR, PS-10-DC	•		
	114-HP	Push	1000	2 3/16	(56.0)	70	(31.7)	S-10-SNR, S-10-DNR, S-10-SN, PS-10-SNR, C-2510, PS-10-DC	•		
	114-HM	Magazine	2000	1 1/2	(57.0)	64	(29.0)		•		
2"	200-HT	Thread on	500	3	(76.2)	64	(29.0)	S16-SN, S16-SNR	•		
	200-HTL	Thread on	250	3	(76.2)	50	(23.0)	S16-SN, S16-SNR,	•		
	200-HT MAXLOK	Thread on	500	3	(76.2)	100	(45.4)	S16-SFC, PSFC-S16		•	
	200-HTL MAXLOK	Thread on	300	4 1/2	(114.3)	80	(36.3)	S16-SFC, PSFC-S16		•	

Custom-Branded Seals

Make your mark!

Samuel Packaging Systems Group offers custom logo printing on all seals.

PLASTIC STRAPPING SEALS

Seals for Plastic Strapping

Strap Size in (mm)	Seal No.		Seal Type	Std. Pack		Seal Length		Wt. Per Pack		Recommended Tools
	Can.	U.S.		Can.	U.S.	in (mm)	in (mm)	lbs (kg)	lbs (kg)	
3/8 (10)	3-0	3-0	Open	2000	1000	1 1/4 (32)	1 1/4 (32)	15 (6.8)	7.5 (3.4)*	
	3-T	-	Thread-On	2000	-	1 1/4 (32)	1 1/4 (32)	16 (7.3)	-	
1/2 (13)	4-0	4-0	Open	2000	1000	1 1/4 (32)	1 1/4 (32)	20 (9.1)	10 (4.6)*	C-3004
	40S	-	Serrated	1000	-	1 1/4 (32)	1 1/4 (32)	21 (9.5)	-	SSPET-331-S
	-	40	Open	-	1000	1 1/4 (32)	1 1/4 (32)	-	-	C-3004
	-	-	-	-	-	-	-	10 (4.6)*	-	-
5/8 (16)	4-T	-	Thread-On	2000	-	1 1/4 (32)	1 1/4 (32)	21 (9.5)	-	C-3004
	4-403-TC	4-M	Thread-On	1000	1000	1 1/4 (32)	1 1/4 (32)	15 (6.8)	-	P403-4, SSPET-331-S
	5-0	5-0	Open	2000	1000	1 1/4 (32)	1 1/4 (32)	22 (10.0)	11 (5.0)	
3/4 (19)	50S	-	Serrated	1000	-	1 1/4 (32)	1 1/4 (32)	23 (10.5)	-	SSPET-330-S
	5-T	-	Thread-On	2000	-	1 1/4 (32)	1 1/4 (32)	24 (11.0)	-	S-5, S-5-HD
	5-404-TC	5-M	Thread-On	1000	1000	1 1/4 (32)	1 1/4 (32)	21 (9.5)	-	P404-5, SSPET-330-S
	6-0	6-0	Open	1000	1000	1 1/4 (32)	1 1/4 (32)	13 (6.0)	-	S-6, S-6-HD
60S	-	-	Serrated	1000	-	1 1/4 (32)	1 1/4 (32)	25 (11.4)	-	SSP-380-S
	6-T	6-T	Thread-On	1000	-	1 1/4 (32)	1 1/4 (32)	14 (6.4)	-	S-6

*U.S. specifications only

Wire Buckle



Plastic Buckle



Metal Seal



Heat Seal



Friction Weld



Plastic Buckles – Regular Duty

Type	Size			
	Can.	U.S.	in (mm)	(mm)
PL-4	—	—	1/4-1/2	(6-13)
PL-5	—	—	5/8	(16)
PL-6	—	—	3/4	(19)

Polyester Cord Strapping

	Type	Size in (mm)	Strength		Coil Size I.D.xWxD.		Coil Length	
			lbs (kg)	lbs (kg)	in (mm)	in (mm)	ft (m)	ft (m)
Q Strap Light Duty	QS20	1/4 (6)	350 (159)	350 (159)	3 x 5 1/2 x 12 (76.2 x 139.7 x 304.8)	7800 (2380)		
	QS30	3/8 (10)	475 (215)	475 (215)	3 x 5 1/2 x 12 (76.2 x 139.7 x 304.8)	5250 (1600)		
	QS40	1/2 (13)	680 (308)	680 (308)	3 x 5 1/2 x 12 (76.2 x 139.7 x 304.8)	3900 (1190)		
	QS50	5/8 (16)	792 (359)	792 (359)	3 x 5 1/2 x 12 (76.2 x 139.7 x 304.8)	3000 (915)		
	QS60	3/4 (19)	950 (431)	950 (431)	3 x 5 1/2 x 12 (76.2 x 139.7 x 304.8)	2100 (640)		
Weatherguard Heavy Duty	20WG	1/4 (6)	540 (245)	540 (245)	3 x 5 1/2 x 13 (76.2 x 139.7 x 330.2)	8250 (2560)		
	30WG	3/8 (10)	780 (355)	780 (355)	3 x 5 1/2 x 13 (76.2 x 139.7 x 330.2)	5000 (1520)		
	40WG	1/2 (13)	1050 (475)	1050 (475)	3 x 5 1/2 x 13 (76.2 x 139.7 x 330.2)	4160 (1270)		
	50WG	5/8 (16)	1310 (595)	1310 (595)	3 x 5 1/2 x 13 (76.2 x 139.7 x 330.2)	3300 (1010)		
	60WG	3/4 (19)	1585 (720)	1585 (720)	3 x 5 1/2 x 13 (76.2 x 139.7 x 330.2)	2500 (760)		
Weatherguard Extra Heavy Duty	45WG	1/2 (13)	1360 (620)	1360 (620)	3 x 5 1/2 x 12 (76.2 x 139.7 x 304.8)	3300 (1010)		
	55WG	5/8 (16)	1650 (750)	1650 (750)	3 x 5 1/2 x 12 (76.2 x 139.7 x 304.8)	2500 (760)		
	65WG	3/4 (19)	1830 (830)	1830 (830)	3 x 5 1/2 x 12 (76.2 x 139.7 x 304.8)	1665 (500)		
32mm Wide Weatherguard Woven	105WG	1 1/4 (32)	3285 (1490)	3285 (1490)	3 1/2 x 1 1/4 x 18 (88.9 x 32 x 457.2)	660 (200)		
Woven Wide	W020	1/4 (6)	350 (160)	350 (160)	3 x 5 1/2 x 12 (76.2 x 139.7 x 304.8)	7800 (2380)		
	W030	3/8 (9)	475 (215)	475 (215)	3 x 5 1/2 x 12 (76.2 x 139.7 x 304.8)	5250 (1600)		
	W040	1/2 (13)	680 (310)	680 (310)	3 x 5 1/2 x 12 (76.2 x 139.7 x 304.8)	3900 (1190)		
	W050	5/8 (16)	792 (360)	792 (360)	3 x 5 1/2 x 12 (76.2 x 139.7 x 304.8)	3000 (915)		
	W060	3/4 (19)	950 (430)	950 (430)	3 x 5 1/2 x 12 (76.2 x 139.7 x 304.8)	2100 (640)		
Extra Heavy Duty	125WOJ	1 1/2 (38)	5400 (2455)	5400 (2455)	3 x 1 1/2 x 19 (76.2 x 38.1 x 482.6)	480 (147)		
Weatherguard Extra Heavy Duty Woven	65WO	3/4 (19)	1830 (830)	1830 (830)	3 x 5 1/2 x 12 (76.2 x 139.7 x 304.8)	1665 (500)		

Polyester Cord Strapping

Custom printed Cord strap available on request. Standard colour white: optional colours, blue, green, yellow, rust, black.

Wire Buckles – Heavy Duty

Type	Size			
	Can.	U.S.	in (mm)	(mm)
CB4	—	—	3/8-1/2	(10-13)
CB6	—	—	5/8-3/4	(16-19)
CB10A	—	—	1 1/4	(32)
CB32	—	—	1 1/4	(32)
CB38	—	—	1 1/4	(32)

Wire Buckles – Regular Duty

Type	Size			
	Can.	U.S.	in (mm)	(mm)
C4	—	—	1/4-1/2	(6-13)
C5	—	—	5/8	(16)
C6	—	—	3/4	(19)

STEEL STRAPPING TENSIONERS

Feedwheel Tensioners

For general use on flat surfaces, feedwheel tensioners feature fast and easy operation. With unlimited take-up, the strapping is pulled through the tool until the desired tension is obtained.

Push-Type Tensioners

These tools are for use on small or irregular shaped surfaces. Using push-type seals, the tensioner pushes against the seal without any part of the tool coming between the strap and the package.

Windlass Tensioners

These tools are used for heavy tensioning applications such as rail car or truck loading. The strap passes through the slotted windlass drum for positive heavy tension.

Pneumatic Tensioners

With speed and ease of operation, these tools feature reversing or non-reversing motors with unlimited feedwheel take-up.

The pusher type is for use on irregular-shaped surfaces.

The feedwheel type is ideal for flat surfaces of all sizes. It is available in two tension ranges and has an optional cutter attachment.

Manual Steel Strapping Tensioners

Model		Strap Size		Weight		Description
Can.	U.S.	in	(mm)	lbs	(kg)	
T-34-F	T-34-F	1/2 - 3/4 x .028	(13-19 x .71)	4.4	(2.0)	Feedwheel – Medium to Heavy Tension
A301-10	A-301	1 1/4 x .029-.044	(32 x .74-1.12)	7.1	(3.2)	Feedwheel – Heavy Duty
A301-19	A301	3/4 x .025 to .035	(19 x .64-.89)	4.4	(2.0)	
A402	A-402	1 1/4 x .029-.044	(32 x .74-1.12)	8.8	(4.0)	Feedwheel – Push Type Heavy Duty
T-4-P	T-4-P	3/8 - 3/4 x .023	(10-19 x .58)	2.0	(0.9)	Push Type – For Light Tension
T-6-P	T-34-P	3/8 - 3/4 x .025	(10-19 x .64)	5.1	(2.3)	Push Type – Medium Duty
T-10-P	T-114-P	3/4 - 1 1/4 x .035	(19-32 x .89)	5.3	(2.4)	Push Type – Heavy Duty
T-10-HP	T-10-HP	3/4 - 1 1/4 x .050	(19-32 x 1.27)	7.3	(3.3)	



Feedwheel tensioners with unlimited take-up

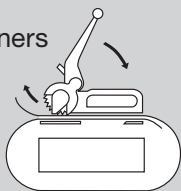

Push-type tensioners for irregular shaped packages

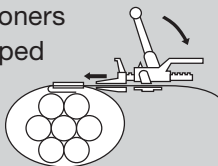

Windlass tensioner for heavy duty use

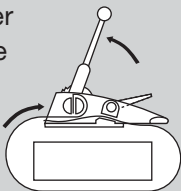

Pneumatic Steel Strapping Tensioners

Model	Strap Size		Weight		Description
	in	(mm)	lbs	(kg)	
A452-6/10	3/4 - 1 1/4 x .025-.050	(19-32 x .64-1.27)	9.6	(4.4)	Pneumatic Pusher Type – For curved or irregular shaped packages. Heavy Duty.
A453	2 x .044	(52 x 1.144)	10.34	(4.7)	Free wheeling system. Extremely high tension.



A452-6/10
(A453 for 2" strap available)

STEEL STRAPPING SEALERS

Manual Steel Strapping Sealers

Model		Strap Size		Weight		Description
Can.	U.S.	in	(mm)	lbs	(kg)	
S-3-0		3/8 x .015-.020	(10 x .38-.51)	2.2	(1.0)	Double Down-Notch Front Action
SA12-0		1/2 x .015-.023	(12 x .38-.58)	2.2	(1.0)	
SA58-0		5/8 x .015-.023	(16 x .38-.58)	2.2	(1.0)	
SA34-0		3/4 x .015-.023	(19 x .38-.58)	2.2	(1.0)	
S-3-P		3/8 x .015-.020	(10 x .38-.51)	2.2	(1.0)	Single Up-Notch Front Action
S-4-P		1/2 x .015-.023	(12 x .38-.58)	2.2	(1.0)	
S-5-P		5/8 x .015-.023	(16 x .38-.58)	2.2	(1.0)	
S-6-P		3/4 x .015-.023	(19 x .38-.58)	2.2	(1.0)	
S6-SNR	S-34-SNR	3/4 x .025-.035	(19 x .64-.89)	5.5	(2.5)	Single Up-Notch
S10-SNR	S-114-SNR	1 1/4 x .031-.035	(32 x 1.12-1.27)	13.2	(6.0)	
SA11-D6	S-34-DNR	3/4 x .028-.035	(19 x .71-.89)	6.6	(3.0)	Double Up-Notch
SA11-D10	S-114-DNR	1 1/4 x .025-.035	(32 x .64-.89)	6.6	(3.0)	
B250		2 x .044-.050	(51 x 1.12-1.27)	15.4	(7.0)	Single Friction Crimp



Standard Duty Sealers

Double notch down-cut sealers yield high joint efficiency. They are usually used with feedwheel type tensioners on regular shaped packages.

Single notch up-cut sealers are ideal for use on irregular packages. They are usually used with push-type tensioners.

Heavy Duty Sealers

Ruggedly built for trouble-free service with Heavy Duty or High Tensile strapping. Up notch sealers are usually used with push or thread-on type seals. Down notch sealers can be used with most seal types except crimp. Crimp sealers are always used with special crimp type seals.



SA11-D6 (S6-DNR)
US: S-34-DNR

SA11-D10 (S10-DNR)
US: S-114-DNR



Pneumatic Steel Strapping Sealers

Model	Strap Size		Weight		Description
	in	(mm)	lbs	(kg)	
NSP1435	1 1/4 x .029-.035	(32 x .74-.89)			Crimp Sealer
N-1444-50LSH	1 1/4 x .044-.050	(32 x 1.12-1.27)			Double Crimp
A461-19x.64	3/4 x .025	(19 x .51)	9.3	(4.2)	Double Up-Notch
A461-19x.79-.89	3/4 x .029-.035	(19 x .74-.89)	9.3	(4.2)	
A461-32x.79-.89	1 1/4 x .029-.035	(32 x .74-.89)	9.3	(4.2)	
NS-250-65L	2 x .044-.050	(51 x 1.12-1.27)	6.6	(3.0)	Heavy duty, Single Crimp

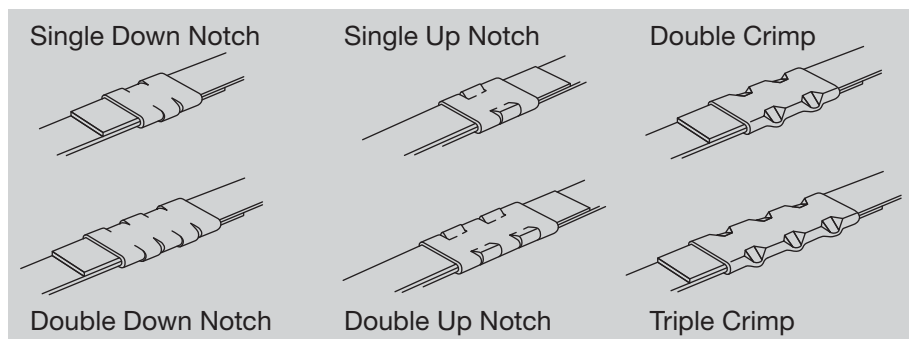

A461

SEAL AND SEALLESS STEEL STRAPPING COMBINATION TOOLS

Samuel Sealless Systems enable you to perform tensioning, sealing and cutting in one simple operation, without the need for separate tools. By eliminating metal seals, our Sealless Systems provide significant savings on your overall strapping costs and increase your operating productivity. These systems are reliable, with proven track records in all types of applications. The Sealless System has been approved by the Association of American Railroads (AAR) and meets or exceeds Government specifications.

Manual Tools

These lightweight, versatile performers can be operated with ease and maximum efficiency in any position, with two handle control of tensioning, sealing and cut off.



Pneumatic/Manual Tools

These pneumatic tensioning, manual sealing combination tools are lightweight. The primary benefit of this Sealless tool is that no suspension is required, allowing a larger work area to be covered.



Pneumatic Tools

For rapid and reliable strapping applications, our pneumatic tools are usually suspended for convenient use and are often installed with a semi-automatic strapfeeder. Two buttons control the entire operation of tensioning, sealing and cut-off.



Manual Steel Strapping Combination Tools – Seal Type

Model	Strap Size		Weight		Description
	in	(mm)	lbs	(kg)	
A431-3	3/8 x .015-.020	(10 x .38-.51)	7.5	(3.4)	Manual Pusher Type for Round Packages, and Irregular Shapes
A431-4	1/2 x .015-.023	(13 x .38-.58)	7.5	(3.4)	
A431-5	5/8 x .015-.023	(16 x .38-.58)	7.5	(3.4)	
A431-6	3/4 x .015-.023	(19 x .38-.58)	7.5	(3.4)	

Pneumatic Steel Strapping Combination Tools – Seal Type

A480-3	3/8 x .015-.020	(10 x .38-.51)	9.3	(4.2)	Pneumatic Pusher Type for Round Packages, and Irregular Shapes
A480-4	1/2 x .020-.023 H.T.	(13 x .51-.58)	9.3	(4.2)	
A480-5	5/8 x .020-.023 H.T.	(16 x .51-.58)	9.3	(4.2)	
A480-6	3/4 x .020-.025 H.T.	(19 x .51-.64)	9.3	(4.2)	
A482-6	3/4 x .031 H.T.	(19 x .79)	14.3	(6.5)	
A483-10	1 1/4 x .029-.035 H.T.	(32 x .74-.89)	41.9	(19.0)	
A483-25	1 x .035 H.T.	(26 x .89)	41.9	(19.0)	

Manual Steel Strapping Combination Tools – Sealless Type

A332-3	3/8 x .015-.020 S.D.	(10 x .38-.51)	7.5	(3.4)	Manual Sealless Operation for Standard Duty Steel Strapping
A335-4	1/2 x .020-.023 H.T.	(13 x .51-.58)	8.6	(3.9)	Manual Sealless Operation for High Tensile Steel Strapping
A335-5	5/8 x .020-.023 H.T.	(16 x .51-.58)	8.6	(3.9)	
A335-6	3/4 x .020-.023 H.T.	(19 x .51-.58)	8.6	(3.9)	
A337-4	1/2 x .015-.025 H.T.	(13 x .38-.63)	9.8	(4.4)	Manual Sealless Operation for High Tensile Steel Strapping
A337-5	5/8 x .015-.025 H.T.	(16 x .38-.63)	9.8	(4.4)	
A337-6	3/4 x .015-.025 H.T.	(19 x .38-.63)	9.8	(4.4)	
A338-4	1/2 x .020-.023 H.T.	(13 x .51-.58)	12.1	(5.5)	Manual Sealless Operation for High Tensile Strapping
A338-TW-4	1/2 x .020-.023 H.T.	(13 x .51-.58)	13.0	(5.9)	
A338-5	5/8 x .020-.023 H.T.	(16 x .51-.58)	12.1	(5.5)	High Tension
A338-TW-5	5/8 x .020-.023 H.T.	(16 x .51-.58)	13.0	(5.9)	TW: Torque Wrench
A338-6	3/4 x .020-.025 H.T.	(19 x .51-.64)	12.1	(5.5)	Tension Lever
A338-TW-6	3/4 x .020-.025 H.T.	(19 x .51-.64)	13.0	(5.9)	
SL114	1 1/4 x .025-.031	(32 x .64-.79)	11.0	(5.0)	Heavy Duty

Semi-Pneumatic Steel Strapping Combination Tools – Sealless Type

A391-4	1/2 x .020-.023 H.T.	(13 x .51-.58)	11.2	(5.1)	Pneumatic Tensioning and Manual Sealing for High Tensile Steel Strapping
A391-5	5/8 x .020-.023 H.T.	(16 x .51-.58)	11.2	(5.1)	
A391-6	3/4 x .020-.023 H.T.	(19 x .51-.58)	11.2	(5.1)	

Pneumatic Steel Strapping Combination Tools – Sealless Type

A385-4	1/2 x .020-.023 H.T.	(13 x .51-.58)	23.1	(10.5)	Pneumatic Sealless Operation for High Tensile Steel Strapping
A385-5	5/8 x .020-.023 H.T.	(16 x .51-.58)	23.1	(10.5)	
A385-6	3/4 x .020-.025 H.T.	(19 x .51-.64)	23.1	(10.5)	
A380-4	1/2 x .020-.023 H.T.	(13 x .51-.58)	38.4	(17.4)	Pneumatic Sealless Operation for High Tensile Steel Strapping Heavy Duty
A380-5	5/8 x .020-.023 H.T.	(16 x .51-.58)	38.4	(17.4)	
A380-625	3/4 x .020-.025 H.T.	(19 x .51-.64)	38.4	(17.4)	
A380-631	3/4 x .020-.031 H.T.	(19 x .51-.79)	38.4	(17.4)	
A383-10	1 1/4 x .029-.035 H.T.	(32 X .74 -.89)	51.0	(23.1)	

PLASTIC STRAPPING TOOLS

Powered Plastic Strapping Combination Tools

Model	Strap Type	Strap Size		Weight		Description
		in	(mm)	lbs	(kg)	
P328	Polyester or Polypropylene	3/8 x .016 - .041 to 5/8 x .016 - .041	(10 x .40-1.05) (16 x .40-1.05)	9.3	(4.2)	4.0 Ah Li-Ion battery
P329	Polyester or Polypropylene	5/8 x .026 - .053 to 3/4 x .026 - .053	(16 x .65-1.35) (19 x .65-1.35)	9.3	(4.2)	4.0 Ah Li-Ion battery
P331	Polypropylene	3/4 x .024 - .060 to 1 1/4 x .0124 - .060	(19 x .80-1.53) (25 x .40-1.35)	12.6	(5.7)	3.0 Ah Li-Ion battery
P355	Polyester or Polypropylene	3/8 x .016 to 5/8 x .041	(10 x .4) (16 x 1.04)	10	(4.75)	Pneumatic tension and friction sealing
P356	Polyester	5/8 x .026 to 3/4 x .053	(16 x .65) (19 x 1.35)	11.9	(5.4)	Pneumatic tension and friction sealing

* When ordering battery charger, refer to model number P326/P327/P330.



P328/P329



P331

Manual Plastic Strapping Combination Tools

Model		Seal		Strap Size		Weight		Description
Can.	U.S.	Can.	U.S.	in	(mm)	lbs	(kg)	
P403-4	P403	4-403-TC	4-M	1/2	(13)	7.5	(3.4)	Manual drum type combination tensioning and sealing tool
P404-5	P404	5-404-TC	5-M	5/8	(16)	8.4	(3.8)	



P356

Polyester Cord Strapping Tensioners

Model	Description
T6-C	Manual drum-type tensioner with shear for 3/8 - 3/4" (10mm-19mm) strapping
CET40	Manual drum-type tensioner with shear for 1 1/4 - 1 1/2" (32mm-38mm) strapping
CUP60	Manual push-type tensioner for 3/8 - 3/4" (10mm-19mm) strapping
CET19	Economy Tool
CAT19	Medium duty pneumatic tensioner to 3/4" (19mm)
CAT32	Heavy Duty pneumatic tensioners to 1 1/4" (32mm)



P403/404

Manual Plastic Strapping Tensioners

Model	Weight		Description
	lbs	(kg)	
SSPP-360-T	1.1	(0.5)	For up to 5/8" (16mm) polypropylene strapping. Flat and curved surfaces.
CET-19R	1.1	(0.5)	Push-type for up 3/4" (19mm) polypropylene and cord strapping. Curved surfaces.
SSP-320-T	3.5	(1.6)	For up to 3/4" (19mm) plastic strapping. Flat surfaces.
SSPET-370-T	6.6	(3.0)	For up to 1 1/4" (32mm) polyester strapping. Flat surfaces.



SSP-320-T

Manual Plastic Strapping Sealers

Model	Weight		Description
	lbs	(kg)	
C-3004	1.1	(0.5)	For 1/2" (13mm) polypropylene strapping.
SSPET-331-S	4.4	(2.0)	For 1/2" (13mm) polyester strapping.
SSPET-330-S	4.4	(2.0)	For 5/8" (16mm) polyester strapping.
SSP-380-S	7.1	(3.2)	For 3/4" (19mm) plastic strapping.

DISPENSERS/CUTTERS

100-5 Standard Dispenser for Steel or Plastic Strapping

- Portable dispenser for standard oscillated wound coils of steel strap 27/8" (70mm) wide and coils of plastic strap with 16" core and 3" or 6" face
- Complete with strap guide and extra-large tool tray

100-6 Standard Dispenser for Steel or Plastic Strapping

- Portable dispenser for standard oscillated wound coils of steel strap 27/8" (70mm) wide and coils of plastic strap with 16" core and 3" or 6" face
- Strap guide, extra-large tool tray, and trolley brake
- Hand truck style for maneuverability

*1000H Extra Rugged Dispenser for Steel and Plastic Strapping

- Heavy duty dispenser with reinforced frame
 - Accepts standard oscillated wound coils of steel strap 27/8" (70mm) wide and coils of plastic strap with 16" core and 3" or 6" face
 - Extra-large tool tray with reinforced supports
 - Hand truck style for maneuverability
 - Heavy duty trolley brake and wheels for demanding environments
- *Tools not included*

200-21 Ribbon Wound Steel Strapping Dispenser

- Heavy gauge welded steel frame with hardened steel rollers for smooth coil payoff and longer life
- Manually adjustable for strap sizes of 3/4" (19mm), 1 1/4" (32mm) or 2" (52mm)
- Strap payoff is to the side

*1000P Ribbon Wound Steel Strapping Dispenser

- Heavy gauge welded steel frame with rugged rollers for smooth coil payoff and longer life
 - Manually adjustable for strap sizes of 3/4" (19mm), 1 1/4" (32mm) or 2" (52mm)
 - Strap payoff is to the side
- * Tools not included*

100-7-G Horizontal Dispenser for Oscillated Wound Steel Strapping

- Made of heavy gauge steel
- Spun bucket is bearing-mounted for easy strap payoff
- Strap payoff is from inside of the coil

100-9 Dual Ribbon Wound Coil Dispenser

- Holds two ribbon wound coils of 2" (52mm) strap
- Has foot-operated shear to cut two straps per stroke



Cutters

SLDS

Light duty, for strapping up to 1 1/4" x .039 (38mm x 1mm)



SMDS - 1

Medium duty, for strapping up to 2" x .035 (50.8mm x .88mm)



SMDS

Heavy duty, for strapping up to 2" x .050 (50.8mm x 1.27mm)



SHDS

Heavy duty, for strapping up to 1 1/4" x .065 (38mm x 1.65mm)



ACCESSORIES



Tool Balancer

Balancers

- Suspend strapping tools at desired levels, from a fixed overhead position on a ceiling, monorail or jib crane
- Several models to choose from depending on balancing and weight required

Standard Duty

Type		Weight Capacity	
Can.	U.S.	lbs	(kg)
BF9	EW-5	6-9	(2.7-4.1)
BF13	EW-9	9-13	(4.1-5.9)
BF18	EW-15	13-18	(5.9-8.2)
BF24	EW-15	18-24	(8.2-10.9)

Heavy Duty

Type		Weight Capacity	
Can.	U.S.	lbs	(kg)
EB25000	EW-15	18-25	(8.2-11.4)
EB35000	EW-22	25-35	(11.4-15.9)
EB45000	EW-22	35-45	(15.9-20.5)
50JA	-	40-55	(18.1-24.9)



HLC-80 Scrap Chopper

Scrap Chopper

- Cuts strapping or wire from the lightest to the heaviest gauges into 3 1/2" (88.9mm) lengths.
- Makes disposal fast and simple.
- Various models, including electric or gas driven motors, are available to suit your applications.



Cut-to-length Strap Dispenser

Cut-To-Length Strap Dispenser

- Accurately cuts 3/8" (10mm) through 2" (51mm) strapping in lengths from 0.10 (2.54mm) to 99.99" (254cm)
- Automatic operation reduces labour costs and eliminates waste
- Models for steel and plastic strapping

Accessories for Polyester Cord Strapping

Item	Description
21-475	Super Shears
CRF-10	Lacing Rod

Accessories

Item	Size		Pieces Per Box	Weight Per Box	
	in	(mm)		lbs	(kg)
Edge protector CP-34-CR	1" leg x 15/8" W	(25.4 x 41.3)	1000	33	(15.0)
Edge protector CP-34-PL	1" leg x 11/4" W	(25.4 x 31.3)	1000	7	(3.2)
Edge protector CP-114-PL	1 3/4" leg x 2 1/4" W	(44.5 x 57.2)	1000	29	(13.2)
Edge protector CP-114-CR	2" leg x 2 15/16" W	(50.8 x 74.6)	500	50	(22.8)
Anti skid plate	3 3/8" W x 4 3/4" L x .060	(85.7 x 120.7 x 1.5)	200	50	(22.8)
Staples J-34	7/8" W x 5/8" L x 14GA	(22.2 x 15.9 x 355.6GA)	9400	50	(22.8)
Staples J-114	1 3/8" W x 3/4" L x 12GA	(34.9 x 19.1 x 304.8GA)	6100	50	(22.8)



Fibre edge protector



CP-34-CR



CP-114-CR



CP-114-PL



Anti-skid plate



Staple

STRETCH WRAP EQUIPMENT

Samuel manufactures and markets the complete range of stretch wrap equipment and systems for all your unitizing requirements. Capable of producing up to 90 pallets per hour, Samuel's manual, semi-automatic and fully-automatic systems (platform or conveyORIZED) are available to suit a variety of needs. A powered pre-stretched film delivery system is available for most models.



Defender LP

This sturdy, low profile semi-automatic stretchwrapper is a bestseller for midsize wrapping operations where reliable packaging and an affordable price are essential to the bottom line.

Production Rate:	up to 40 loads per hour
Max. Load Size:	52"W x 52"W x 90"H
Max. Load Weight:	4000 pounds
Voltage:	115 VAC, 15 amp
Warranty:	3 year parts, lifetime on pre-stretch rollers
Shipping Weight:	1400 lbs



Defender HP

This high profile workhorse has been designed for challenging plant environments where debris from daily production can gather on the shop floor. The raised turntable ensures that the machine continues its output of 30-40 loads an hour without risk of problems from scrap material on the floor.

Production Rate:	up to 40 loads per hour
Max. Load Size:	52"W x 52"W x 80"H
Max. Load Weight:	4000 pounds
Voltage:	115 VAC, 15 amp
Warranty:	3 year parts, lifetime on pre-stretch rollers
Shipping Weight:	1000 lbs



Defender RT

The Defender RT rotary arm stretch wrapper has been designed for loads that would be difficult to wrap with a turntable machine. With its standard wrap heights of 84" and 96", the Defender RT can wrap extremely heavy or unstable loads directly on the floor.

Electrical Supply:	110/220, 20 amp
UL/CSA:	Approved components
Load Size:	50" x 50"
Load Heights:	20" to 80"
Load Weights:	Up to 4000 lbs
Production:	20-25 loads per hour (depending on configuration)

SRA 650

Full Automation makes this rotary arm wrapper ideal for conveyORIZED systems. With entry and exit conveyors, the product can be staged before the machine. The SRA 650 can be supplied as a stand-alone system or integrated with other equipment such as strappers and palletizers.



Electrical Supply:	220V, 1 phase, 20 amp
UL/CSA:	Approved components
Load Size:	50" x 50"
Load Heights:	20" to 80"
Load Weights:	Up to 4000lbs
Production:	40-60 loads per hour (depending on configuration)

Features and specifications subject to change without notice

STRETCH FILM

Machine Stretch Film

Roll Width		Thickness		Rolls Per Pallet
in	(mm)	Gauge	(Micron)	
20-30	(508-762)	40-200	(10.16-50.8)	16-40

Hand Stretch Film

Roll Width		Thickness		Cases Per Pallet
in	(mm)	Gauge	(Micron)	
3-20	(76.1-508)	60-90	(15.2-22.8)	18-48

Platinum Max Machine Film

Features

Cast co-extruded multi-layer
 High stretch – 300%
 Excellent load retention
 Superior puncture resistance
 High clarity
 Exceptional cling without
 added tackifiers
 Excellent tear resistance
 Excellent machine performance

Benefits

Maximum film performance
 Reduced package cost
 Reduced shifting – tighter package
 Improved product protection
 Easy product identification
 Crystal clear – quiet payoff
 No zipper if tear occurs
 – maintain integrity
 Fewer breaks – less downtime

Platinum Max High Performance Machine Stretch Film

Roll Width		Thickness		Rolls Per Pallet
in	(mm)	Gauge	(Micron)	
20-30	(508-762)	39-110	(9.9-27.9)	25-50

Platinum Max Hand Film

Key Characteristics

- Utilizes new resin & extrusion technology
- Highest puncture resistance in the industry possible without film break
- Higher holding force versus all conventional and micron hand films
- Thinnest/Strongest film in the industry

Platinum Max High Performance Hand Stretch Film

Roll Width		Thickness		Cases Per Pallet
in	(mm)	Gauge	(Micron)	
12	(304.8)	33-55	(8.4-14)	64-80
14	(355.6)	33-55	(8.4-14)	64-80
16	(406.4)	33-55	(8.4-14)	64-80
17.7	(449.6)	33-55	(8.4-14)	64-80

Standard Films

Samuel Packaging Systems Group Stretch Film features consistently high quality and superior performance. Available in a variety of widths and gauges, our films have an excellent stretch memory and unsurpassed puncture resistance. This can lower your palletizing costs without affecting unitizing strength and load integrity.

Platinum Max Films

Samuel Packaging Systems Group is pleased to introduce the next generation of high performance stretch films - Platinum Max High Performance Stretch Films. Utilizing new resin and extrusion technology, these new films offer ultimate performance with tremendous puncture and tear resistance.

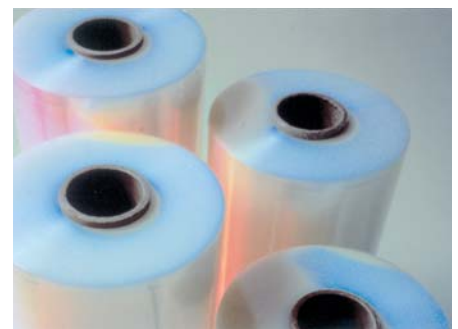
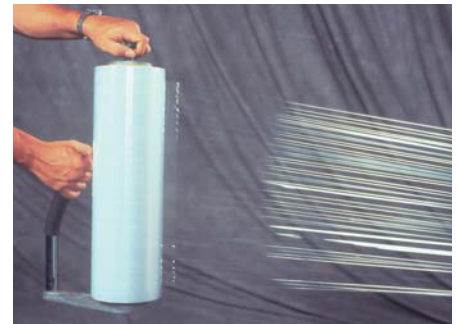

Go Green  with **SAMUEL**
1855
 PACKAGING SYSTEMS GROUP

**Thinner film = less film waste....
 save up to 20%!**

ECONOMY PLASTIC STRAPPING MACHINES

Our series of economy strapping machines are ideal for low volume or light duty applications where full automation or high speeds are not necessary. These machines offer many labour saving features that can increase productivity in your packaging operation with only a small investment.

I-10



The all new I-10 semi automatic strapping machine is your economic solution for package bundling. This table top unit can run anywhere from 5mm to 15.5mm polypropylene strapping and is ready to operate in only 45 seconds. With little moving parts, this machine is the economical choice for being easy to maintain and keeping operation costs low.

I-10 Semi-Automatic Strapping Machines				
Dimensions	30 ³ / ₄ " (780mm)W	30 ¹ / ₂ " (775mm)H	21 ³ / ₈ " (543mm)D	100 lbs (45kg)
Table Height	29 ¹ / ₂ " (750mm)			
Package Size	Max(WxH) Free		Min(WxH) 3 ⁷ / ₈ x 1 ¹ / ₈ " (100 x 30mm)	
Strap Width	1/4, 3/8, 1/2, 5/8" (5, 6, 9, 12, 15.5mm)			
Strap Tension	Up to 88 lbs (40 kg)			
Power Supply	100-120, 220-240V, 1phase 50/60Hz			

D-53X2



The D-53X2 is the second-generation belt-less strapping machine, featuring an upgraded microprocessor which improves tension control. Using a steel wheel, tension can be applied to a high level without scuffing the strap. Easy adjustment of tension from 4.4 lbs to 100 lbs makes the D-53X2 a versatile strapping machine for any light application.

D-53X2 Semi-Automatic Strapping Machines				
Dimensions	30 ¹ / ₁₆ " (780mm)W	30 ¹ / ₂ " (750mm)H	21 ³ / ₄ " (556mm)D	110 lbs (50kg)
Table Height	29 ⁹ / ₁₆ " (750mm)			
Package Size	Max(WxH) Free		Min(WxH) 3 ¹⁵ / ₁₆ x 1 ¹ / ₄ " (100 x 30mm)	
Joint/Strap/Coil	heat seal/polypropylene/ID200 x OD450 x W200mm			
Strap Width	1/4, 3/8, 1/2, 5/8" (5, 6, 9, 12, 15.5mm)			
Strap Tension	4.4-110lbs (2-50 kgf)			
Power Supply	100, 220, 240V, 1phase 50/60Hz 0.4KVA			

JK-5000



The JK-5000 High Speed Automatic Strapping Machine is the perfect solution for fast paced environments that require an arch strapping machine. With a strapping speed of up to 37 straps/minute, the JK-5000 is 32% faster than the JK-5. The JK-5000 can easily be converted to run polypropylene straps from 5mm up to 12mm in width and uses a heat seal to secure the load.

JK-5000 Automatic Strapping Machines				
Dimensions	36 ¹ / ₂ " (921mm)W	52 ¹ / ₂ " (1336mm)H	23 ¹ / ₂ " (600mm)D	238 lbs (108kg)
Table Height	33 ¹ / ₂ " (827mm)			
Package Size	Max(WxH) 25 x 15" (650 x 400mm)		Min(WxH) 2 ³ / ₈ x 1-1/4" (60 x 30mm)	
Sealing Method	heat seal			
Strap Width	1/4, 3/8, 1/2" (5, 6, 9, 12mm)			
Strap Tension	up to 88lbs (up to 40 kgf) stroke 11 ³ / ₈ " (300mm)			
Power Supply	100, 120, 200, 220, 230, 240V, 1phase 50/60Hz 0.65KVA			

AQ-7



Capable of 27 straps per minute, the AQ-7 offers proven reliability and durability at an inexpensive price. The machine uses many parts from the RQ-8 series machines, giving it the ability to reliably run 5mm and 6mm strapping. The AQ-7 features the same lubrication free operation as the RQ-8. Using cost efficient 3-phase power, the motors run only when necessary.

AQ-7 Automatic Strapping Machines				
Dimensions	49 ⁵ / ₁₆ " (1252mm)W	55 ¹ / ₄ " (1403mm)H	24" (610mm)D	396 lbs (180kg)
Table Height	31 ⁵ / ₁₆ " (795mm)			
Package Size	Max(WxH) 24 ⁷ / ₁₆ x 18 ⁷ / ₈ " (650 x 500mm)		Min(WxH) 3 ¹ / ₈ x 1 ¹ / ₄ " (80 x 30mm)	
Joint/Strap/Coil	heat seal/polypropylene/ID200 x OD450 x W200mm			
Strap Width	1/4, 3/8, 1/2, 5/8" (5, 6, 9, 12, 15.5mm)			
Strap Tension	Max. 154 lbs (70 kgf) stroke 3 ¹ / ₈ " 80mm			
Power Supply	200, 220, 240, 380, 400, 415V, 3phase 50/60Hz 0.85KVA			

RQ-8 AUTOMATIC STRAPPING MACHINES

The RQ-8 series of strapping machines is the most dependable series of strapping machines ever developed. Their innovative design makes them the most reliable line of general purpose plastic strapping machines on the market.

Capable of up to 48 straps a minute, the RQ-8 series features automatic strap loading, auto refeed and loop ejection, lubrication free operation, dual tensioning and self-diagnostic microprocessor control. This machine series has a reputation as having the lowest maintenance costs of any machine available.

A wide range of options is available to customize the RQ-8 to meet the needs of your operation, including custom arch sizes and configurations. The machines shown below are found in many common industrial applications. For custom configurations, contact your local sales representative.

RQ-8X



The RQ-8X is the evolution of one of Samuel's most popular and longest selling models, the RQ-8. The new RQ-8X offers a higher strapping speed along with the same reliability, intuitive operation and ease of maintenance that the market has come to expect. These features reinforce the market leading position of the RQ-8 series machines.

RQ-8X Automatic Strapping Machines				
Dimensions	49 1/4" W (1252mm)	55 1/4" H (1403mm)	24" D (609mm)	353 lbs (160kg)
Table Height	31 1/4" (794mm)			
Arch Size – (WxH)	Standard Arch Size (650mm wide x 500mm high or 25" wide x 20" high)			
Package Size	Max – (WxH) 24 1/2 x 18 7/8" (620 x 480mm)			
	Min – (WxH) 3 1/8 x 1 1/4" (80 x 30mm)			
Joint/Strap/Coil	heat seal/polypropylene/ ID 8" x OD 18" x W 8" (ID200 x OD450 x W200mm)			
Strap Width	1/4, 3/8, 1/2, (5/8)" (5, 6, 9, 12, (15.5)mm)			
Power Supply	100, 120, 200, 220, 230, 240V single phase 50/60Hz 0.9KVA			

RQ-8000



Another successor to the venerable RQ-8, the RQ-8000 offers a higher strapping speed, as well as an integrated Foot Bar, Height Adjustment and a built in Cycle Counter. The RQ8000 reinforces the market leading position of the RQ-8 series machines.

RQ-8000 Automatic Strapping Machine				
Dimensions	50" W (1500mm)	56 1/4, 57 1/2, 58 5/8, 59 7/8, 61" H (1429, 1459, 1489, 1519, 1549mm)	24" D (610mm)	384 lbs (180kg)
Table Height	32 1/4, 33 1/2, 34 5/8, 35 7/8, 37" 820, 850, 880, 910, 940mm			
Package Size	Max – (WxH) 24 1/2 x 18 7/8" (620 x 480mm)			
	Min – (WxH) 3 1/8 x 1 1/4" (80 x 30mm)			
Joint/Strap/Coil	heat seal/polypropylene/ ID 8" x OD 18" x W 8" (ID200 x OD450 x W200mm)			
Strap Width	1/4, 3/8, 1/2, (5/8)" (5, 6, 9, 12, (15.5)mm)			
Power Supply	100, 120, 200, 220, 230, 240V single phase 50/60Hz 0.9KVA			

RQ-8IR3



Designed for the graphic arts, magazine, news distribution and direct mail industries, this variant of the RQ-8 runs inexpensive 5mm and 6mm strapping and can achieve speeds of 60 bundles per minute without compromising tension strength.

RQ-8IR3 High Speed Printing and Mailing Strapping Machine			
Dimensions	41 3/8" W (1052mm)	56 7/8" H (1445mm)	24" D (609mm)
Table Height	36 7/8" (936mm)		
Arch Size – (WxH)	25" x 16 (650 x 400 mm)		
Package Size	Max – (WxH) 24 1/2 x 19" (620 x 500mm)		
	Min – (WxH) 3 1/8 x 1 1/8" (80 x 30mm)		
Strap Width	1/4" (5, 6mm)		
Strap Tension	up to 77 lbs (35kg)		
Speed	Up to 60 straps per min.		
Power Supply	100-120, 200-240V, Single Phase		

STAINLESS STEEL STRAPPING MACHINES

RQ-8MP



The RQ-8MP boasts all of the advanced features of the RQ-8, such as strap self-loading, refeed, and loop ejection, but adds an attractive and practical stainless steel body. The RQ-8MP can be built in most of the configurations available in the RQ-8 series. It brings the speed and performance of the RQ-8 into the poultry and meat processing industry.

RQ-8MP Stainless Steel Strapping Machine				
Dimensions	57 ¹ / ₈ " (1452mm)W	59 ¹ / ₈ " (1503mm)H	24" (609mm)D	388 lbs (175kg)
Table Height	31 ¹ / ₄ " (794mm)			
Arch Size (WxH)	33"x 24" (850 x 600mm)			
Min. Package Size (WxH)	3 ¹ / ₈ " x 1 ¹ / ₈ " (80 x 30mm)			
Strap Width/Type/Seal	1/4, 3/8, 1/2, 5/8" (5, 6, 9, 12, 15.5mm) / Polypropylene / Heat Seal			
Strap Tension	784N (80kgf) or 150mm stroke, 178 lbs or 6" stroke			
Speed	1.8 sec/strap			
Core Size	8" x 8" or 9" x 8" (ID 200 or 230 X W200mm)			
Power Supply	100-120, 220-240V, 1phase 50/60Hz, 0.65KVA			

D-53M2



The D-53M2 is the perfect machine for low volume applications in the seafood, poultry, meat and other food processing industries. The table height is adjustable to different positions: 732 mm (28⁷/₈") or 642 mm (25¹/₄") from the floor.

D-53M2 Stainless Steel Strapping Machine				
Dimensions	42 ¹ / ₂ " (1078mm)W	58 ³ / ₄ " (1493mm)H	24 ³ / ₈ " (620mm)D	166 lbs (75kg)
Table Height	25 ¹ / ₄ - 28 ⁷ / ₈ " (642 - 732mm)			
Min. Package Size (WxH)	1 ¹ / ₈ " x 3 ¹ / ₈ " (30 x 80mm)			
Strap Width/Type/Seal	1/4, 3/8, 1/2, 5/8" (5, 6, 9, 12, 15.5mm) / Polypropylene / Heat Seal			
Strap Tension	400N (40kgf) (88 lbs)			
Core Size	8" x 8" or 9" x 8" (ID 200 or 230 X W200mm)			
Power Supply	100-120, 220-240V, 1phase 50/60Hz, 0.4KVA			

JK-5SUS



The JK-5SUS is ideal for low-volume applications in food and medical industries where sanitation and minor moisture exposure is a concern. The JK-5SUS is a bottom seal model with a stainless steel body. The bottom of the body cabinet is reinforced and shielded to provide extra protection where moisture exposure is the greatest.

JK-5SUS Stainless Steel Strapping Machine				
Dimensions	36 ¹ / ₈ " (919mm)W	52 ⁵ / ₈ " (1336mm)H	23 ⁵ / ₈ " (600mm)D	222 lbs (100kg)
Table Height	32 ¹ / ₂ " (827mm)			
Arch Size (WxH)	25"x 16" (650 x 400mm)			
Min. Package Size (WxH)	2 ³ / ₈ " x 1 ¹ / ₈ " (60 x 30mm)			
Strap Width/Type/Seal	1/4, 3/8, 1/2, 5/8" (5, 6, 9, 12, 15.5mm) / Polypropylene / Heat Seal			
Strap Tension	392N (40kgf) or 300mm stroke, 88 lbs or 12" stroke			
Speed	2.2 sec/strap			
Core Size	8" x 8" or 9" x 8" (ID 200 or 230 X W200mm)			
Power Supply	100-120, 220-240V, 1phase 50/60Hz, 0.56KVA			

RQ-7000M



The RQ-7000M automatic plastic strapping machine is the powerhouse of the RQ series. It boasts the advanced, high-speed sealing head of the RQ-7000, the durability of the AQ-7M in moisture-laden environments, and the convenient features of the RQ-8, which include strap self-loading, refeeding, and loop ejection.

RQ-7000M Stainless Steel Strapping Machine				
Dimensions	62 ¹ / ₄ " (1580mm)W	70" (1772mm)H	26" (664mm)D	484 lbs (220kg)
Table Height	24 ¹ / ₂ , 25 ¹ / ₄ , 26" (624, 642, 664mm)			
Arch Size (WxH)	27 ¹ / ₂ " x 25" (700 x 650mm)			
Min. Package Size (WxH)	1 ¹ / ₄ " x 3 ¹ / ₈ " (30 x 80mm)			
Strap Width/Type/Seal	1/4, 3/8, 1/2" (5, 6, 9, 12mm) / Polypropylene / Heat Seal			
Strap Tension	690N (70kgf) or 150mm stroke, 155 lbs or 6" stroke			
Speed	1.2 sec/strap, 50 straps/min.			
Core Size	8" x 8" or 9" x 8" (ID 200 or 230 X W200mm)			
Power Supply	200-240, 380-480V, 3 phase 50/60Hz, 0.69KVA			

CODING AND LABELING

Samuel Packaging Systems Group provides all of the products you need to create, print, and apply labels, bar codes, control tags, and marking systems. As coding and labeling equipment specialists, we create product ID systems that provide total solutions for your product marking and management needs. We offer standard and customized systems to suit any application, and work with you every step of the way: from system design to installation to training to maintenance.

PLASTIC PRODUCTS



CONCRETE PRODUCTS



METALS



CODING AND LABELING

WOOD PRODUCTS

Pulp Bales

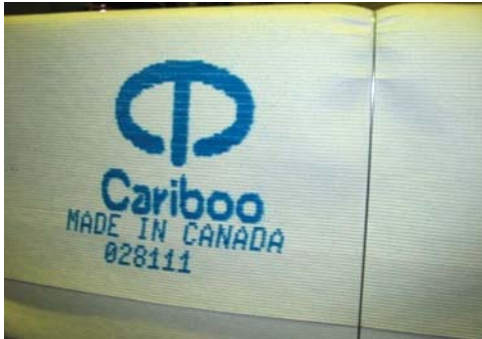

Fully Automatic In Line Bar Coding



PANEL PRODUCTS



INKJET GRADE MARKING



INKJET STENCIL PRINTING

Lumber



OSB

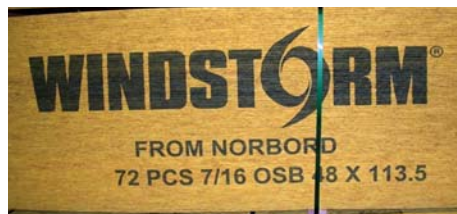

Plywood



FULLY AUTOMATED MACHINE SYSTEMS

SBC-932



The SBC-932 Fully Automatic Strapping System is ideal for bulk loads of containers. There are 4 compression choices available to provide the best package for your application. The SBC-932 features the fast and reliable VK-20 strapping head. The heavy duty heater knife has a cycle life in excess of 900,000 cycles, which insures strong consistent welds and low maintenance. Independent motors, which simplify maintenance and eliminate the need for multiple clutch assemblies drive the major functions of the VK-20 head.

SBC-932 Side Seal Strapping Machine

Electrical	460V, 3hp, 60hz
Air	80 psi
Strapping	Polyester
Strap Size	3/8"(9 mm) - 3/4"(19 mm)
Standard Package Size* Min	26" H, 40" W
Max	110" H, 60" W
Standard Conveyor Height*	9" up to 20"

* Alternative track sizes and conveyor heights are available.

SCU-8 Unitizer



The SCU8 uses high performance heads and components to produce securely unitized corrugated loads to meet your specific requirements. The SCU8's framework is built from structural steel to withstand a lifetime of use in demanding plant environments. The heavy steel platen and reinforced under conveyor supports allow high compression forces on corrugated loads. Our standard model offers compression up to 8000 lbs, with higher levels available as an option. The SCU8 comes equipped with the VK20 strapping head, which offers you the flexibility to use polyester or polypropylene strap in 3/8" to 1/2" gauges with only minor onsite adjustments. The user-friendly programmable controllers are state-of-the-art and provide an O.E.M. system suitable for interfacing with any standard conveyor equipment.

SCU-8 Corrugated Unitizing Machine

Max. Load Height	80" or 88"
Min. Load Height	10" or 18" (with optional Pallet Void feeders the minimum height is 18")
Max. Load Width	102"
Min. Load Width	24"
Through Clearance	102"
Compression	1,000 to 8,000 lbs. Range (Higher levels optional)
Compression Sys.	Hydraulic
Maximum Diagonal	102"
Package Dimension	87" L x 102"W
Roller Conveyor	Internal Powered
Head Spacing	15" and 24"
Machine Height	127"
Machine Width	87"

SLP-25



Samuel's standard lumber press offers a rugged modular design that has made it the machine of choice for demanding mill environments. Structural steel tubes make this machine the strongest and heaviest in its class and allow it to resist torsional stresses during compression. Automatic bunk carriage magazines and flat fibre edge protector dispensers ensure complete package protection and total automation. The SLP-25 can be outfitted with a seamless G9 head for steel strapping or a VK30 heat seal head for polyester strapping. This versatile system can be further enhanced by adding a jumbo dispenser to handle 1000lb steel coils or 160 lb jumbo polyester coils. The SLP-25 can also strap panel products with the panel option installed.

SLP-25 Lumber Strapping Machine

Machine Opening	Max. 56" (1422mm)
Height	Min. 8" (205mm)
Machine Opening	Max. 58" (1473mm)
Width	Min. 22" (560mm)
Strapping Size	1/2, 5/8 and 3/4" from .020 up to .040 in. thick) (12.7mm, 16mm and 19mm from 0.5mm up to 1mm thick)
Strap Joint	Highest joint efficiency in the industry
Compression	Adjustable up to 25,000 lbs (111,200 newtons) top and 25,000 lbs (111,200 newtons) side

DISPENSERS FOR FULLY AUTOMATED EQUIPMENT



CD-12J Polyester Strapping Dispenser

The Samuel CD-12J Strap Dispenser is designed to meet the demands of today's high performance polyester unitizing machines. The versatile drum will hold multiple coil sizes as a standard feature. With an optional easy loading jib and c-hook attachment, the CD-12J will handle Jumbo Coils up to 160 lbs. A high torque 3 phase gear motor and V.T. drive ensure smooth drum rotation and high performance strap delivery.



CD-12SJ Jumbo Polyester Strapping Dispenser

The Samuel CD-12SJ Dispenser has been designed specifically for high output facilities that can benefit from our Super Jumbo polyester strapping coils. With coil lengths up to 20000 feet for $\frac{5}{8}$ x .040 and 17500 feet for $\frac{3}{4}$ x .040 strapping many facilities can run several shifts without changeovers. The CD-12SJ has been designed to hold the 208 lb coils and features an easy loading jib and c-hook attachment, A high torque 3 phase gear motor and V.T. drive ensure smooth drum rotation and high performance strap delivery.



SCD-12 Steel Strapping Dispenser

The Samuel SCD-12 Strap Dispenser is designed to meet the demands of today's high performance steel strapping machines. The versatile drum will hold multiple coil sizes as a standard feature. With an optional easy loading jib and c-hook attachment, the SCD-12 will handle coils up to 100 lbs. A high torque 3 phase gear motor and V.T. drive ensure smooth drum rotation and high performance strap delivery.



HD-13 Jumbo Steel Strapping Dispenser

The Samuel HD-13 Jumbo Steel Coil Dispenser is designed for the demands of today's high output facilities. The large capacity turntable carries up to three coils, reducing downtime in your plant due to changeovers. With a heavy duty thrust bearing for smooth turntable rotation, and roller chain drive, the HD-13 will keep your efficiency high and your packaging costs low.

EDGEBOARD

Specifications

Wings		Thickness		Length	
in	(mm)	in	(mm)	in	(mm)
1 x 1	25 x 25	0.060 - 0.400	1.524 - 10.160	2 - 100+	50.80 - 2540+
1 1/2 x 1 1/2	38 x 38	0.060 - 0.400	1.524 - 10.160	2 - 100+	50.80 - 2540+
2 x 2	50 x 50	0.060 - 0.400	1.524 - 10.160	2 - 100+	50.80 - 2540+
2 1/2 x 2 1/2	60 x 60	0.060 - 0.400	1.524 - 10.160	2 - 100+	50.80 - 2540+
2 x 3	50 x 76	0.060 - 0.400	1.524 - 10.160	2 - 100+	50.80 - 2540+
2 x 4	50 x 100	0.060 - 0.400	1.524 - 10.160	2 - 100+	50.80 - 2540+
3 x 3	76 x 76	0.060 - 0.400	1.524 - 10.160	2 - 100+	50.80 - 2540+
4 x 4	100 x 100	0.060 - 0.400	1.524 - 10.160	2 - 100+	50.80 - 2540+

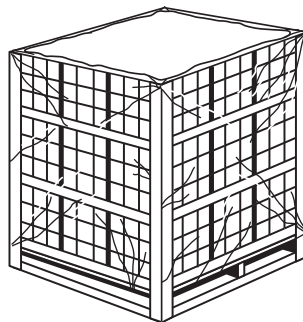
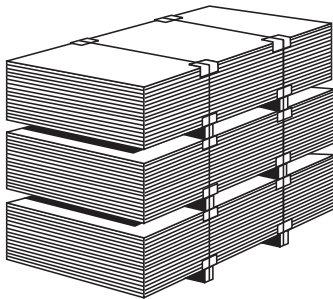
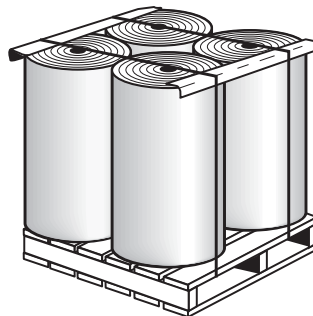
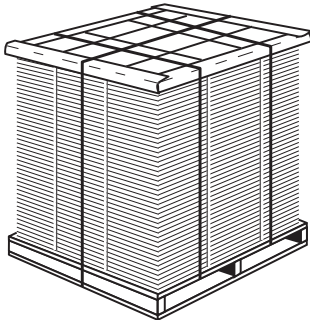
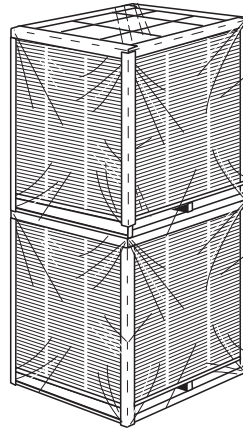
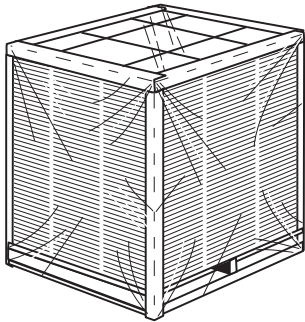

Samuel Edgeboard and Edge Protectors are made from several plies of paperboard that are glued, treated and formed into a rigid right angle.

Samuel Edgeboard serves to protect edges of pallet loads and adds stacking strength to packages.

Edgeboard is used to reinforce packages both externally and internally. It is also used for unitizing and stabilizing pallet loads.

Samuel Edgeboard is available in various lengths and calipers. Edge protectors range from 2 1/2" (63.5mm) to 11.5" (292mm) in length and are boxed and sold per thousand pieces. Edgeboard is available up to 228" (579.1mm), is palletized, and sold per thousand linear foot/1000m.

A significant freight savings can be achieved by combining edgeboard with steel and/or plastic strapping. By combining the products, the bulk paper product moves at the lower steel rate.

Advantages

- Over-wrapped quality finish
- Robust
- Multi color printing on premises
- Easy use
- Interweaved packaging
- White, brown or printed finish

Applications

- Used in food, furniture, pharmaceutical, aviation, fruit and vegetables growers industries, etc.

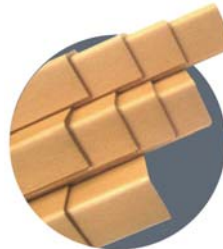

Classic over-wrapped Kraft finish corner edge protectors, recyclable, with or without logo



Water resistant over-wrapped corner edge protectors with plastic finish for humid or wet applications



Standard over-wrapped white corner edge protectors Matte or glossy finish



Short pieces over-wrapped corner edge protectors (1-4 inches)

DUNNAGE BAGS

Samuel's Reuseable SuperFlow Air Bag is a Fast, Easy and Cost Effective System for Reducing Load Damage.

The SuperFlow system efficiently secures loads in trailers, railcars, vessels and ocean containers, enabling you to maximize your load securement dollars by reusing the airbags multiple times where applicable. 100% recyclable, our Superflow bags are the environmentally friendly choice for securing your loads.

Reusable

- By pushing our unique, patented blue valve flapper, operators can quickly deflate the air bag and store it for reuse.



The Air Bag

- Manufactured with high-quality kraft paper.
- Zebra stripes allow operators to determine whether the bag is the correct size for the void.
- Braces your load, creating a bulkhead to ensure optimum load security

The Valve

- Large diameter opening enables quick inflation.
- Blue flap depresses for rapid deflation.
- Easy to lock/unlock cap prevents air loss and eliminates the pulling, pushing or twisting typically required to seal other valves.



Consistent

- By setting the desired pressure on the air line regulator, you can achieve consistent inflation.
- Once the desired level of air pressure has been achieved, the SuperFlow inflator ceases to inflate the air bag. This reverses the air flow and redirects it out the back of the inflator, indicating the bag is properly inflated, preventing over-inflation.
- The SuperFlow air bag reduces the risk of load damage and operator injuries. The Zebra stripes on the air bag help operators to determine whether the correct air

bag size is being used in the void, ensuring maximum load security.

Fast

- A 48" x 48" air bag can be inflated in only 8 seconds.
- The SuperFlow inflator is unique, utilizing both compressed and ambient air (Venturi Effect), enabling it to achieve unparalleled inflation speeds.

Without A Load Securement System



With Samuel SuperFlow Air Bags



- The large diameter of our patented valve significantly reduces inflation and deflation time.



The Inflator

- Available with attached pressure gauge.
- Simple design for easy operation and minimal parts.
- Durable for industrial environments.



Cost Effective

- The SuperFlow air bag can be used multiple times, significantly reducing the cost per use.
- The SuperFlow air bag can be inflated in less than half the time of the competition, enabling your operators to spend less time securing loads. This improves your operation's efficiency and reduces labor costs.
- Quick deflation reduces labor costs at the receiving end.

BALERS/WIRE PRODUCTS

The Samuel Series of Balers

The Samuel series of balers are designed for trouble free and efficient baling of any compressible recycling material. With their ability to compress paper, cardboard, cloth, plastics, and non ferrous metals, these versatile balers are ideal for customers in retail, industrial and commercial applications. The simple but rugged design of the Samuel series of balers, ensures years of low maintenance operation in even the harshest environments. Simple controls and instructions allow safe operation of the machine by workers of all skill levels.

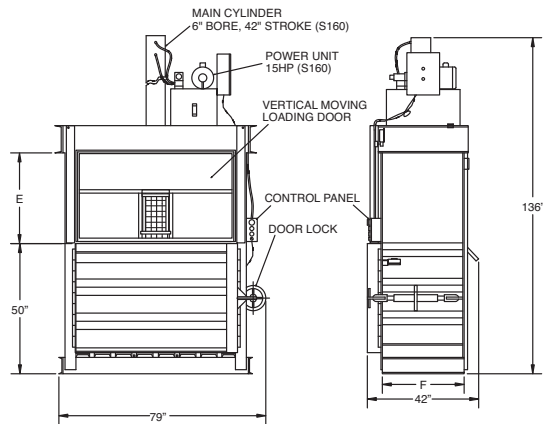

Standard 60" Baler

Baling Wire

Samuel Baling wire is used in a wide variety of applications on recycled products like paper, plastic, metal and clothing. We have a complete range of top quality baling wire available. Our products range from;



50lb & 100lb Boxed coils

- Single loop wire – assorted lengths and gauges
- Double loop wire – assorted lengths and gauges
- Fully annealed boxed wire in 50lb coils (45 to a skid) and 100lb coils (36 to a skid)
- Fully annealed bulk stem wire averaging 750kgs per stem
- A comprehensive range of galvanized bulk stem wire in assorted specifications
- Super Soft – averaging 625kgs per stem
- High tensile - averaging 625kgs per stem
- Marathon and custom packaging available on some products



Single Loop Wire



Bulk Stem



PRODUCTS & SERVICES

Steel, polypropylene and polyester strapping
Seals
Heavy duty industrial unitizing systems
Heavy duty steel and plastic strapping heads
Manual and pneumatic strapping tools
Semi and fully automatic strapping machines
Stretch wrap machines
Cutters
Dispensers
Edgeboard
Scrap choppers

© May 2017 - 121011

Major Operating Locations

Canada

ALBERTA

7032 - 68 Avenue
Edmonton AB T6B 3C5
Tel: 780-469-4040

BRITISH COLUMBIA

1365 Derwent Way
Annacis Island
New Westminster, B.C. V3M 5V9
Tel: 604-521-3700
Tel: 1-800-667-1264

MANITOBA

2073 Logan Ave - Unit 6
Winnipeg, MB R2R 0J1
Tel: 204-633-3980

NEW BRUNSWICK

115 Whiting Road
Fredericton, NB E3B 4Z9
Tel: 506-459-8898

ONTARIO

2370 Dixie Road
Mississauga, ON L4Y 1Z4
Tel: 905-279-9580
Tel: 1-800-607-8727

735 Oval Court
Burlington, ON L7L 6A9
Tel: 1-800-607-8727

EQUIPMENT DIVISION

21 Corrine Court
Vaughan, ON L4K 4W2
Tel: 905-739-1350

QUEBEC

3289 J.B. Deschamps
Lachine, QC H8T 3E4
Tel: 514-631-5551
Tel: 1-800-361-0900

U.S.A.

ALABAMA

4020 Gault Avenue South
Fort Payne, AL 35967
Tel: 256-845-1928

GEORGIA

110 Dent Drive
Cartersville, GA 30121
Tel: 770-386-8837

ILLINOIS

1401 Davey Road
Suite 300
Woodridge, IL 60517
Tel: 630-783-8900
Parts and Service:
Tel: 1-800-323-4424

OHIO

1455 James Parkway
Heath, OH 43056
Customer Service:
Tel: 1-800-222-1855

SOUTH CAROLINA

2000 K Boyer Drive
Ft. Mill, SC 29708
Tel: 803-802-3203

TEXAS

623 Fisher Rd.
Longview, TX 75604
Tel: 903-759-2761
Tel: 1-800-222-1800
Pine Timbers Dist. Ctr. #2
4660 Pine Timbers Ste 139
Houston, TX
Tel: 713-460-3403

We invite you to experience the Samuel advantage by contacting us today!

packaging@samuel.com

SAMUEL
1855
PACKAGING SYSTEMS GROUP